

PAPER REF: 7232

NEW APPROACH TO SOLVING MATHEMATICAL EQUATION FOR DAMPED OSCILLATIONS BY SLIDING (COULOMB) FRICTION AT THE KARAKURI MECHANISM

Tomas Riegr, Ivan Masin^(*)

Technical University of Liberec, Faculty of Mechanical Engineering, Czech Republic

^(*)*Email: ivan.masin@tul.cz*

ABSTRACT

Calculation of the time course and speed of the oscillation motion dampened by centripetal force typically represented by sliding friction is rather complicated mathematical task, which is unnecessary to solve repeatedly for individual stages of the given oscillations until they are completely subdued. The fact that said damping friction force changes its direction of action depending on the direction of movement of the mechanism considerably complicates given solution. To solve the motion equation of such a mechanism, the mathematical software MAPLE using the SIGNUM function is being used.

Keywords: damped oscillations, sliding (Coulomb) friction, Karakuri, trolley, mechanism, MAPLE software.

INTRODUCTION

The matter of calculating oscillations with constant (Coulomb) friction is not too widespread in practise, in contrast to oscillations attenuated by linear (viscous) damping proportional to the first power velocity. With the need for a solution of this type of oscillatory motion we encounter during the design of Karakuri spring mechanisms, which are a perspective solution of differently usable structures capable of its function with the need of minimal supply of external energy, they are working in a so called energy mode. Karakuri mechanisms use their basic physical phenomena such a gravity, magnetism, or energy accumulation into mechanical springs. A spring system that accumulates a portion of the potential energy of the transported body to be later re-used for reverse movement acts as typical oscillator dampened by sliding friction. For this reason, a new calculation method of such mechanism motion equations will be introduced.

RESULTS AND CONCLUSIONS

The use of the signum function in the differential motion equation has been verified on calculations of dynamic behaviour of the trolley for transport of object between two points designed according to Figure 1.

The motion equation of tested Karakuri mechanism (Figure 1) was defined based on (Brat, 1988):

$$m_r^* \ddot{x} + 4k \left(\frac{r_2 r_4}{r_3 r_k} \right)^2 x = [(m_b + m_z)g - 4 F_t] \frac{r_2 r_4}{r_3 r_k} - m_{total} g \frac{\xi}{r_k} \quad (1)$$

The newly modified (1) by usage of sign function for possibility to be simply calculated by the mathematic software:

$$m_r^* \ddot{x} + 4k \left(\frac{r_2 r_4}{r_3 r_k} \right)^2 x + \mathbf{sign}(\dot{x}) \left(4 F_t \frac{r_2 r_4}{r_3 r_k} \right) = (m_b + m_z) g \frac{r_2 r_4}{r_3 r_k} - m_{total} g \frac{\xi}{r_k} \quad (2)$$

Results of equation (2) were solved by using mathematical software with graphical output (Maple, 2014).

The solution of the travelled paths (distance) and the speed depending on time as per:

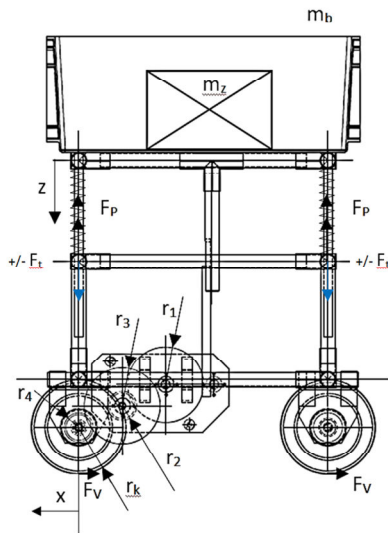

Fig. 1 - 0Experimental Karakuri trolley

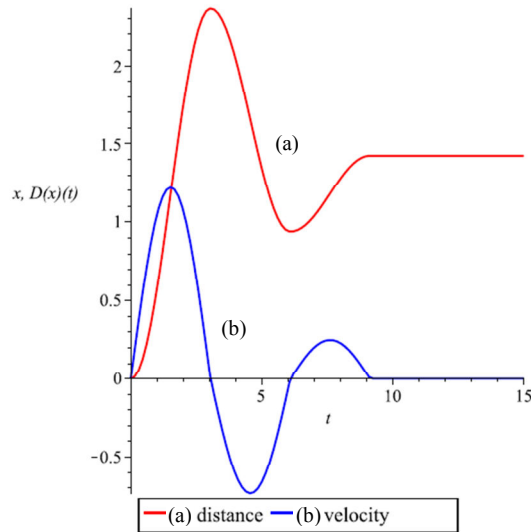

Fig. 2 - Graph of distance and velocity over time

The graph in Figure 2 - moving distance (a) and velocity (b) over time - corresponds to the course of the given parameters measured on the real model.

REFERENCES

- [1] Brat V, Brousil, J. Dynamika (in Czech). Czech Technical Univerzity, Prague, 1988. pp. 79-81.
- [2] Maple Users Manual. 2014. https://www.maplesoft.com/documentation_center/maple18/usermanual.pdf. Web 2. 5 2015.