

PAPER REF: 7148

## **COMMON CAUSE ANALYSIS OF CIRCULAR VARIABLE NACELLE INLET CONCEPTS FOR AERO ENGINES IN CIVIL AVIATION**

**Stefan Kazula<sup>(\*)</sup>, David Grasselt, Klaus Höschler**

Brandenburg University of Technology, Cottbus, Germany

<sup>(\*)</sup>*Email: stefan.kazula@b-tu.de*

### **ABSTRACT**

This paper presents the application of a safe design process within a concept study for variable aero engine inlets. The safety assessment method Common Cause Analysis (CCA), consisting of a Zonal Safety Analysis (ZSA), a Particular Risk Analysis (PRA) and a Common Mode Analysis (CMA), is performed on variable inlet concepts. By the means of the CCA individual failure modes and external events, which can lead to failure conditions, are identified. Potential design adaptations to mitigate these failure conditions are presented.

**Keywords:** variable aero engine inlets, coupled design and safety process, safety and reliability, safety assessment methods.

### **INTRODUCTION**

The product development in the civil aviation industry is driven by the objective of achieving improvements in efficiency, emissions and travel speed, while ensuring safety and reliability (European Commission, 2011). The aero engine and its subsystems, e.g. the inlet, have an influence on these objectives. The efficiency and the flight speed of an aircraft could be increased by using variable aero engine inlets instead of rigid inlets (Baier, 2015). While research studies concerning circular variable inlets with adjustable lip and duct geometry have been performed, e.g. Kondor (2004) and Ozdemir (2015), there are none of them in service in commercial aviation. A reason for this is a potential lack of safety and reliability, as adjustability presents an additional function and thus increased complexity of the system. Therefore, a safety assessment process accompanies the development process, previously described in Kazula (2017), as a part of a feasibility study for variable inlet concepts. The Aerospace Recommended Practices ARP 4754A (SAE Aerospace, 2010) and ARP 4761 (SAE Aerospace, 1996) introduce the safety assessment process and its methods. The application of the methods Functional Hazard Assessment (FHA) and Fault Tree Analysis (FTA) as well as subsequent design adaptations are performed in Kazula (2018).

The CCA is an additional iterative safety assessment method that is performed from early stages of the development process on. A CCA comprises the:

- ZSA to determine hazards by adjacent systems failure modes, maintenance and installation errors,
- PRA to identify external events (SAE Aerospace, 1996), and
- CMA to verify independence of functions.

The process, advantages and limitations of these methods are presented. Additionally, these methods are applied to several concepts for variable inlets, which adjust the inlet geometry by movement of rigid segments.

## VARIABLE INLETS

Aero engine nacelle inlets have to supply the aero engine during each operating condition with the desired quantity of air at a specific uniform flow velocity, while minimising losses due to drag and flow separation. For reasons of safety, flow separations on the inside of the inlet must be avoided under all conditions, as they can ultimately lead to engine surge concatenated with a loss of thrust and reduced durability of the aero engine. Figure 1 illustrates the typical design of modern inlets, which are designed with a fixed trade-off geometry concerning aerodynamic requirements.

On the one hand, the inlet should be highly efficient, e.g. minimising wave and spillage drag, at high flight velocities above Mach 0.8 during cruise operation, what can be achieved by a thin or sharp lip geometry combined with a small entry area  $A_1$  (Farokhi, 2014). On the other hand, flow separations and potentially resulting hazardous events during take-off and climb operation up to Mach 0.3 can be mitigated by utilising a round and thick inlet lip with a large inlet area, however, this would cause higher drag and thus less efficiency at higher flight velocities.

These limitations of conventional fixed inlets can be circumvented by using circular variable inlets that adjust the optimal geometry at each flight condition. This way, efficiency and maximum flight speed can be increased, while avoiding flow separations at take-off and cruise. However, there are no applications of circular variable inlets in modern civil aviation yet. One potential reason for this is that the adjustment of the inlet introduces an additional function, which can entail further reliability and safety issues (SAE Aerospace, 2010).

Hence, variable nacelle inlets for Mach numbers up to 1.6 are investigated focussing on safety and reliability in the context of an internal research project at the Chair of Aero Engine Design at the Brandenburg University of Technology. Within the scope of that project, a methodical safe design approach for variable inlet concepts up to TRL 3 is developed and utilised to perform a feasibility study. The identified concepts can be divided into three geometry adjusting mechanism groups: movement of rigid segments (see Figure 2), deformation of elastic surface material and boundary layer control.

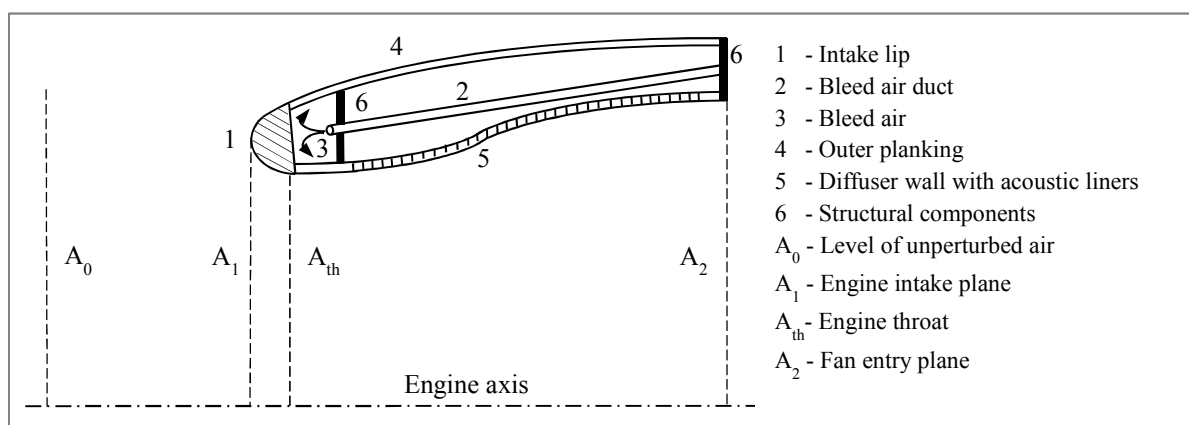

Fig. 1 - Typical design of a rigid subsonic nacelle inlet

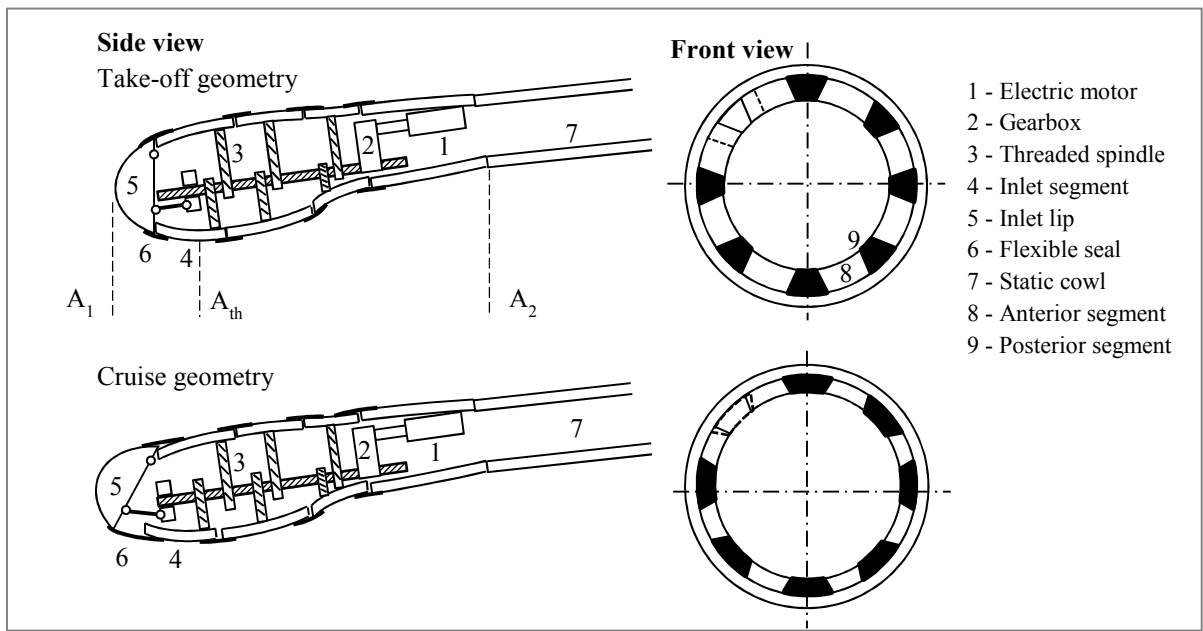

Fig. 2 - Exemplary concept sketch of a variable nacelle inlet

**METHODS**

**Safe Design Approach**

The ARP 4761 (SAE Aerospace, 1996) introduces the safety assessment methods in aviation. Figure 3 presents the allocation of these methods to the design approach of Kazula (2017). The application of the methods FHA and FTA, as well as subsequent design adaptations are described in Kazula (2018). Furthermore, a CCA should be performed to investigate independence issues and external events. The actual analysis focusses on a CCA of concepts that adjust the inlet geometry by movement of rigid segments.

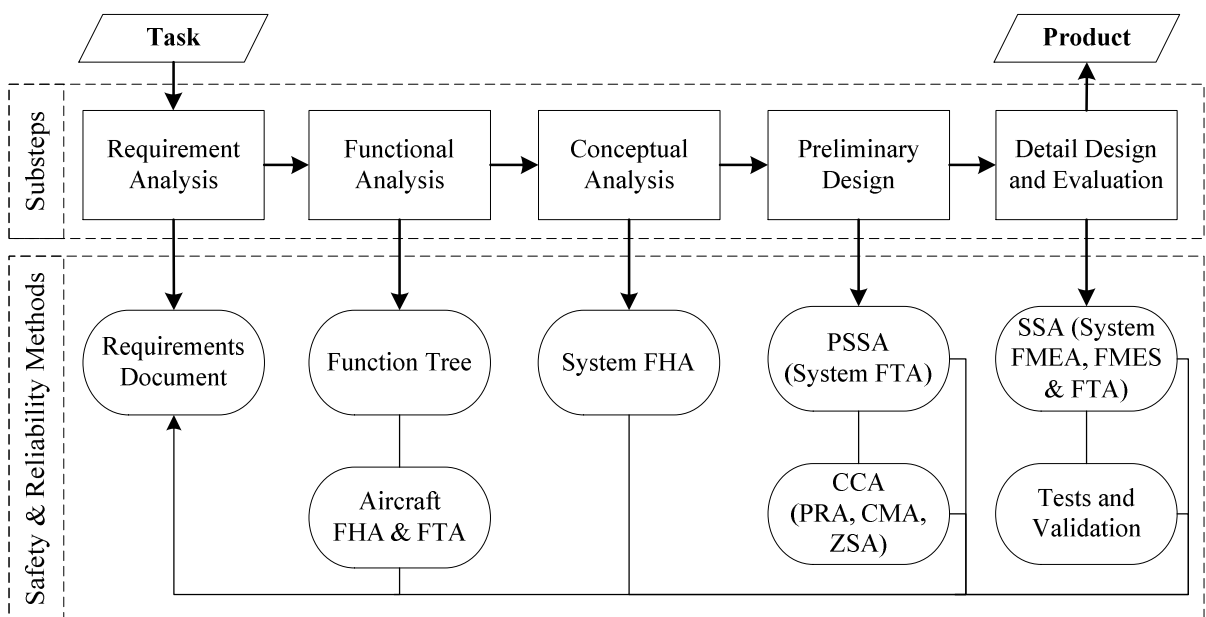

Fig. 3 - Suitable safety and reliability methods for the individual phases of the methodical safe design approach

## Particular Risk Analysis

SAE Aerospace (1996) characterises particular risks as events that happen outside of the immediate system boundaries, but that can affect the requirement according to Certification Specification CS 25.1309 (EASA, 2016) that no single failure event can lead to hazardous conditions. These events can also influence several zones at the same time. Examples for typical events are the following:

- fire,
- high energy devices,
- high pressure air duct rupture,
- high temperature air duct leakage,
- further leaking fluids: fuel, hydraulic oil, water,
- aerodynamic friction,
- friction between moving parts,
- hail, ice, snow, water ingestion,
- icing of operating equipment,
- high ambient temperatures,
- bird strike,
- lightning strike,
- electromagnetic interference,
- high intensity radiated fields and
- bulkhead rupture (SAE Aerospace, 1996; Kritzinger 2016).

Some of these events, e.g. leaking fluids, may also be investigated as a part of the ZSA.

The aim of the PRA is to identify all particular risks concerning the investigated design. After identifying these risks, each risk is examined separately by primarily a qualitative analysis. This way, every safety related effect can be designed out or shown to be acceptable due to its probability of occurrence. The required steps to perform a PRA according to SAE Aerospace (1996) and Kritzinger (2016) are summarised and displayed in Figure 4.

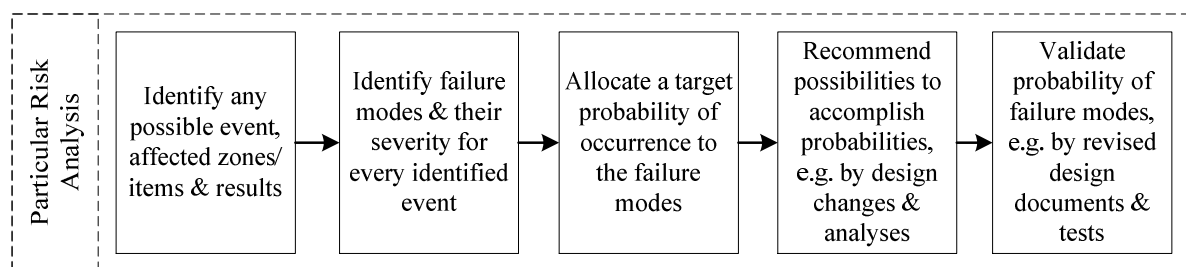

Fig. 4 - Summarised process steps of the Particular Risk Analysis

The PRA should be performed throughout the development process for a new aircraft and for any major modification to the aircraft (SAE Aerospace, 1996). During initial stages of the design process, a PRA can reduce development costs by recognising design weaknesses. As the development process progresses, the design becomes more detailed. Therefore, potential remaining weaknesses can be identified easier. However, mitigation of these weaknesses can only be achieved by more cost-intensive design changes, complex simulations or tests.

On the one hand, a PRA requires a lot of experience to identify all potential events and their effects, as well as high effort and costs to carry out all required analyses and tests. On the other hand, this method enables evaluation of effects of nonrelated systems on each other by crossing system boundaries, allowing the examination of several zones at the same time and facilitating the identification of vulnerabilities to outside interferences (Kritzinger, 2016).

### **Zonal Safety Analysis**

The objective of the ZSA is to prepare guidelines for design and installation, to identify interferences between systems installed in the vicinity, as well as to detect maintenance and installation errors (EASA, 2016). This way, failures can be assured to be independent of other systems or, if not possible, shown to be acceptable with a certain probability of occurrence. A ZSA is a primarily qualitative analysis, which is performed for each zone of the aircraft and should be carried out during the whole development process (SAE Aerospace, 1996). At the beginning of the development process, the ZSA is utilised to create design and installation guidelines and to investigate preliminary drawings or models. During later design phases, the ZSA is based on more detailed design information, e.g. mock-ups and actual components.

The summarised process of the ZSA is illustrated in Figure 5. At the beginning of the ZSA, the preparation of design and installation guidelines should consider aircraft level requirements, results from earlier safety assessments, as well as available maintenance and in-service data from former types. These guidelines can be divided into general, system specific or zone specific. General guidelines for design and installation can comprise

- equipment installation (e.g. including pipes, ducts, hoses, wires, cables),
- component removal and replacement,
- maintenance and servicing, as well as
- drainage guidelines (SAE Aerospace, 1996).

Additionally, zones of the aircraft have to be defined, e.g. according to the Joint Aircraft System/Component (JASC) or the Air Transport Association of America (ATA) code tables. A list of systems and items should be prepared for each zone of the aircraft. The extent of that list is depending on the phase of the development process. Furthermore, failure modes, which could have a safety effect on external systems or items installed in close proximity, should be listed.

Later, each zone of the aircraft is inspected against the design and installation guidelines. Any deviation of the design from these guidelines should be considered for a design change.

The effect of the identified failure modes of systems or items on external systems, items and finally the aircraft should be examined, mitigated and if necessary further evaluated, e.g. within the scope of a Failure Modes and Effects Analysis (FMEA) or an FTA (SAE Aerospace, 1996).

Disadvantages of the ZSA are that it is best done, when all items and systems can be investigated (Kritzinger, 2016). As this is mostly the case during later development phases, required design changes are probably cost intensive. Additionally, this method requires much experience of the investigated system to be performed successfully (Kritzinger, 2016). However, the ZSA is an invaluable safety analysis method to use during system integration. By the means of the ZSA complex potential interactions between systems are considered. Furthermore, potential safety-relevant events from adjacent systems can be identified, e.g. heating pipes near sensitive electronic equipment, hot air leaks and electromagnetic interference effects (Kritzinger, 2016).

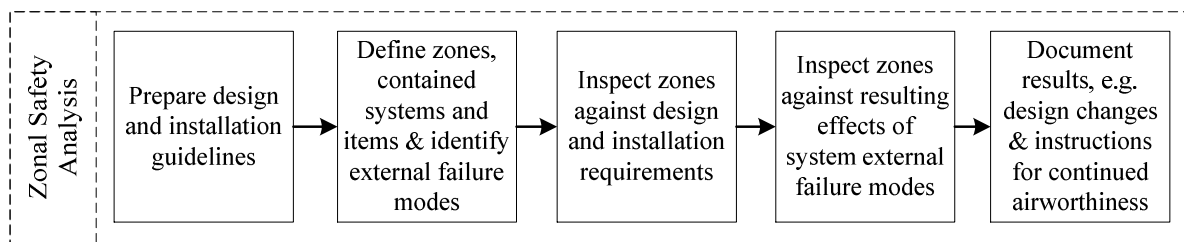

Fig. 5 - Summarised process steps of the Zonal Safety Analysis

### Common Mode Analysis

The CMA is a systematic method that contributes to a safe design throughout the design process. It is a qualitative method for verifying independence of functions and thus events and failure modes. Independence can be achieved by utilising fail-safe or independence principles (Kritzinger, 2006), the most commonly used of them being redundancy, which is the mechanical and electrical segregated duplication of systems or components. However, there are various threats to the independence of redundant systems. Inadvertent dependency can result in even higher failure rates than those of single elements (Lloyd, 1982). Especially, effects of design implementation, manufacturing and maintenance errors, and failures of system components have to be recognised (SAE Aerospace, 1996). For instance, generic faults of a specific hard- or software can cause malfunctions in multiple items that utilise this specific hard- or software (SAE Aerospace, 1996).

The CMA should be conducted throughout the safety assessment process, while being performed best at later stages. This way, inputs from the FHA and the Preliminary System Safety Assessment (PSSA) can be utilised to identify independency issues (SAE Aerospace, 1996). The steps necessary for performing a CMA are illustrated in Figure 6.

At the beginning, a checklist including specific common mode types, sources and failures should be established. Examples for common modes that should be investigated are:

- requirement errors,
- software or hardware development errors,
- hardware failures,
- production or repair flaws,
- installation errors,
- stress related events (e.g. abnormal flight conditions),
- environmental factors (e.g. temperature, vibration, humidity),
- cascading faults and
- common external source faults.

Furthermore, common mode requirements must be identified, e.g. by deriving from an FTA.

Later, the common mode checklist is utilised to analyse the design concerning compliance with the common mode requirements, e.g. independence of functions. This way, it can be ensured that the design meets the common mode requirements. Afterwards necessary design adaptations should be carried out and documented.

Performing a CMA systematically and rigorously can be difficult, as it requires detailed knowledge of the investigated systems and relies on acceptance that unlikely events will occur (Kritzinger, 2016). While the application of a CMA cannot guarantee to identify and

thus to mitigate all common failure modes, it still provides a good approach to identify common development errors. Additionally, it determines functional requirements for separation and isolation of systems (Kritzinger, 2016). Finally, by means of a CMA independence of events can be verified, what supports the selection of the system architecture.

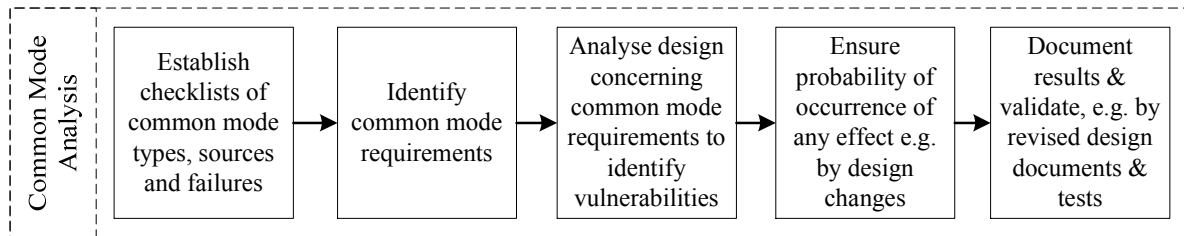

Fig. 6 - Summarised process steps of the Common Mode Analysis

## RESULTS

### Particular Risk Analysis

While many events, e.g. hail impact, have a similar influence on variable inlets like on static inlets, there are still huge differences due to the addition of actuators and sensors, which are required to enable the variation of the inlet geometry. For the investigated concepts, which adjust the inlet geometry by movement of rigid segments, ice, friction between moving parts, bird strike and lightning are among the most critical events. These events, the severity of the particular consequences and the derived probability of occurrence requirements are presented in Table 1. Depending on the selected actuation system, e.g. electric or hydraulic, additional events that have an impact on variable inlets can occur, e.g. fire and leaking hydraulic fluid.

Table 1 - Excerpt from the Particular Risk Analysis (PRA) of variable inlet concepts

Risk	Event	Consequences	Failure mode severity	Probability requirement [Events per flight hour]
<b>Ice</b>	Large ice accumulation on inlet segments of all engines	Potential spalling ice and loss of inlet adjustment capability can affect the inlet flow, damage the fan and potentially cause loss of thrust on all engines.	Hazardous effect during take-off	< 1.0E-07
<b>Bird strike</b>	Strike on inlet lip of a single engine	Impact can damage inlet segments or cause loss of segments. This can affect the inlet flow, damage the fan and potentially cause loss of thrust on a single engine.	Minor effect during take-off	< 1.0E-03
<b>Bird strike</b>	Strike on inlet lip of all engines	Impact can damage inlet segments or cause loss of segments. This can affect the inlet flow, damage the fan and potentially cause loss of thrust on all engines.	Hazardous effect during take-off	< 1.0E-07
<b>Lightning</b>	Direct strike and indirect effects on a single engine.	Damage to segments or seals due to temperature peaks. Damage to actuators and sensors can lead to a loss of control of the inlet adjustment system and thus to loss of thrust on a single engine.	Minor effect during take-off	< 1.0E-03
<b>Friction between moving parts</b>	Friction between inlet segments	Segments getting caught on each other and reduction of material durability can lead to a loss of inlet adjustment capability and thus to loss of thrust on a single engine.	Minor effect during take-off	< 1.0E-03

Severe Icing has a probability of 10<sup>-2</sup> per flight and normal icing can potentially occur during every flight (EASA, 2016; Kritzinger, 2016). Hence, inlet anti-icing systems are usually integrated in modern aircraft. However, these systems mostly cover the area around the inlet lip. Large ice accumulation on the diffuser wall and the outer planking can be prevented by extending the area covered by the anti-icing system. This results in increased heat energy requirements, engineering effort and therefore costs. Furthermore, the relevance of particular risks depends on the chosen anti-icing system. If an electric anti-icing system is preferred, lightning strike and high intensity radiated fields should be inspected more closely. When using bleed air anti-icing systems, high pressure and high temperature air duct leakage should be further examined, as the bleed air temperature can be up to 260°C (SAE Aerospace, 1996).

Bird strikes are a well-known risk in aviation and 37% of them affect the engine or its inlet (Hedayati, 2016). According to CS 25.631 bird strikes must be handled as ultimate loads, which allows for deformation, but not for fracture of inlet segments (EASA, 2016). Consequently, material strengths or thicknesses have to be sufficient. That can result in increased weight, as well as decreased design space and economic efficiency. For successful certification, compliance with CS 25.631 must be shown by analyses and tests.

In the European Union, aircraft get hit by lightning strikes with a frequency of up to 1 strike every 2400 flight hours (Kritzinger, 2016). Negative effects of these strikes must be avoided by utilisation of temperature resistant materials and lightning protection, e.g. by creating a Faraday cage by means of the integration of bonding straps in each inlet segment. Furthermore, electric components, e.g. electric motors, must be grounded.

The friction between inlet segments can be reduced by using coatings or lubrication.

### **Zonal Safety Analysis**

Due to their large extent, only exemplary design and installation guidelines are presented. General design guidelines for equipment installation, e.g. pipes, ducts, hoses, wires and cables, contain requirements for minimising stresses, obstruction and fluid accumulation for both, static and moving parts (SAE Aerospace, 1996). In areas or components, where fluid accumulation can cause fires, corrosion or rot, drainage should be integrated. Furthermore, redundant systems should be segregated to avoid events and failures affecting both systems. Specific design and installation guidelines for a potential hydraulic system require for instance the possibility to manually operate the hydraulic valves and the physical separation of the hydraulic system from the air conditioning system (SAE Aerospace, 1996). Regarding a potential bleed air anti-icing system, wires for transport of energy or position sensor data and the bleed air duct should have a minimum clearance (Kritzinger, 2016). Variable inlet concepts that tend to accumulate dust, dirt or other contamination inside the inlet could require a forced air ventilation to prevent build-up of dust and dirt on component surfaces.

While it is possible to define the whole powerplant or its nacelle as a zone, in the case of this study the variable inlet is considered as a separate zone. This is reasonable, as the inlet can be easily dismantled from the remaining powerplant, given the fact that it is only connected to the nacelle by a flange and some interfaces, e.g. for the anti-icing system. Necessary subsystems in the inlet zone are:

- an inlet lip,
- an outer planking,
- a diffuser wall with acoustic treatment, e.g. Helmholtz resonators,



- an anti-icing system, e.g. bleed air or electric anti-icing,
- an adjustment system, e.g. electric, hydraulic or pneumatic driven, and
- structural components.

These subsystems comprise different components. A bleed air anti-ice system for instance consists of a bleed air duct, a piccolo tube, valves, seals etc., while an electric driven adjustment system requires, among others, actuators, controllers, sensors, wires and cables.

After preparing design and installation guidelines and defining zones and their components, the zones are inspected against the guidelines and any system interferences. Furthermore, resulting effects on the aircraft and potential design precautions to correct, prevent or at least mitigate these issues are considered, see Table 2.

Table 2 - Excerpt from the Zonal Safety Analysis (ZSA) of variable inlet concepts

Component(s) in zone	Potential issue(s) of concern/ failure mode(s)	Effect(s) on the aircraft	Means of correction, prevention or mitigation
<b>Segments of inlet lip, outer planking, and diffuser walls</b>	Accumulations of dust and dirt between movable inlet segments can cause a loss of adjustability of the inlet	An unsuitable inlet geometry can cause flow separations and thus cause loss of thrust on a single engine	Integration of dirt-repellent coatings, ventilation and minimisation of gaps
<b>Bleed air anti- icing system</b>	No bleed air provided by the engine causes ice accumulation on the inlet lip and between inlet segment	Ice accumulation on inlet can affect the inlet flow, damage the fan and potentially cause loss of thrust on all engines	Shed of inlet ice by adjustments of the inlet geometry with low amplitude and medium frequency
<b>Hot surfaces of anti-icing system when using hydraulic driven adjustment system or other flammable fluids</b>	Leakage of flammable fluid close to hot surfaces can cause fire	An uncontrolled fire can result in hazardous effects	Ignition temperature for hydraulic fluids >300°C, ventilation, drainage, potentially integration of fire walls, fire detection and extinguishing system
<b>Electric anti-icing system or electric driven adjustment system</b>	Accumulation of water, e.g. rain or condensing moisture, can damage electric components, cause rot and corrosion and finally loss of adjustability of the inlet	An unsuitable inlet geometry can cause flow separations and thus cause loss of thrust on a single engine	Integration of drainage, grounding of electric components and waterproof component casings, e.g. IP55 (International Protection Code)
<b>Electric wiring, as well as potential bleed air or hydraulic tubes</b>	Adjustment of the inlet lip, outer planking and diffuser wall can cause high stresses in static wires and pipes and damaging them, resulting in loss of adjustability of the inlet	An unsuitable inlet geometry can cause flow separations and thus cause loss of thrust on a single engine	Flexible design of the wiring and anti-ice pipe installation to minimise stresses; minimum clearance between each other
<b>Electric driven adjustment system when using bleed air anti- icing system or electric anti-icing system when using hydraulic driven adjustment system</b>	Leakage of any fluid, e.g. hot air and hydraulic fluid, in proximity to electrical equipment can cause damage to components, fire or loss of adjustability of the inlet	An unsuitable inlet geometry can cause flow separations and thus cause loss of thrust on a single engine, an uncontrolled fire can result in hazardous effects	Over pressure breakout panels, ventilation, drainage and heat protection for the adjusting system, e.g. by means of bulkheads

Due to the results of the ZSA an electric driven actuation system and an electric anti-icing system should be considered for use in variable inlets, as they have the least potential to interfere. However, the various alternatives, like bleed air anti-icing, should be kept under investigation, as they could have a higher economic potential.

Finally, the ZSA is a useful tool to investigate potential interferences within the inlet zone and its proximity. It contributes to the choice of the optimal combination of adjustment and anti-icing system.

### Common Mode Analysis

The first step of the CMA is the preparation of a checklist that includes common mode types, sources and failures, see Table 3. This is best done from the beginning of the design process on to avoid the costly implementation of safety design features during later design phases.

Table 3 - Excerpt from the Common Mode Types, Sources and Failures/Errors Checklist of variable inlet concepts

Common mode types	Common mode sub-types	Example of common mode sources	Example of common mode failures/errors
Concept and design	System architecture	Common external interfaces (e.g. electrical power)	Failure of common sources (e.g. electrical power supply)
Concept and design	System architecture	Equipment protections	Failure due to missing prediction of an event by designers
Concept and design	System architecture	Common software	Software error
Concept and design	Technology	New/sensible technology	General design error due to insufficient experience
Manufacturing	Manufacturer	Common manufacturer	Common error due to manufacturer, e.g. due to inadequately trained staff

This checklist supports the identification of common mode requirements. The most critical failures of the variable inlet system are those affecting all engines. These failures could cause a loss of thrust on all engines and therefore result in hazardous effects, e.g. during take-off (EASA, 2016). A CMA requirement, derived from the FTA in Kazula (2018), is that the inlet adjustment system of engines on the left and on the right side shall be independent. Among others, this requirement has been reviewed during the CMA to mitigate it, see Table 4.

Table 4 - Excerpt from the Common Mode Analysis (CMA) of variable inlet concepts

Requirement: inlet adjustment systems of left- and right-sided engines shall be independent		
Common mode sub-type	Common mode error	Means of correction, prevention or mitigation
System architecture	Local event affecting electrical routes	Use independent electrical routes and connectors (mechanical and electrical segregation of separate sides)
Technology	Development Error	If achievable, utilise conventional technology, perform tests to assure correct operation
Manufacturer	Faulty manufacture affecting similar equipment on both sides	Different manufacturers for each side, certification of manufacturing process and its quality, incoming goods inspection
Environmental factors	Bird strike on both sides	Fall back on a safe geometry when losing adjustment capability

The best way to prevent common mode vulnerabilities, is by using fail safe design principles, see Kritzing (2006), right from the start of the development process.

## **CONCLUSIONS**

By identifying potential single and common events or failures, and application of best possible mitigation methods, the CCA contributes to a safer design of variable inlets. Outputs from the ZSA are the adaptation of the wiring and anti-ice pipe installation, as well as a heat protection for the adjusting system. The risks identified by the PRA are determined, resulting failure conditions are classified and mitigated by design precautions like anti-icing, lightning protection and higher material strengths. The CMA highlights dependence risks mitigated by design principles like redundancy.

While it remains impossible to ensure that every fault is identified during development, this study shows that means of improvement of safety and reliability can be identified by applying a CCA to variable inlet concepts. Compliance with safety and economic requirements are an enabler for the variable inlet technology. Technology introductions like variable inlets in concatenation with coupled design and safety methods are the way to achieve the ambitious ecological, safety and economic goals for future civil aviation.

## **REFERENCES**

- [1] Baier H. Morphelle - Project Final Report. 2015.
- [2] EASA. CS-25 - Certification Specifications and Acceptable Means of Compliance for Large Aeroplanes. EASA, 2016.
- [3] European Commission. Flightpath 2050 - Europe's vision for aviation. Publ. Off. of the Europ. Union, Luxembourg, 2011.
- [4] Farokhi S. Aircraft propulsion. Second edition. Wiley, Chichester, 2014.
- [5] Hedayati R, Sadighi M. Bird strike. An experimental, theoretical and numerical investigation. Woodhead Publishing, Cambridge, 2016.
- [6] Kazula S, Grasselt D, Mischke M, Höschler K. Preliminary Safety Assessment of Variable Nacelle Inlet Concepts for Aero Engines in Civil Aviation. European Safety and Reliability Conference (ESREL), Trondheim, 2018.
- [7] Kazula S, Höschler K. A Systems Engineering Approach to Variable Intakes for Civil Aviation. 7<sup>th</sup> European Conference for Aeronautics and Space Sciences (EUCASS), Milan, 2017.
- [8] Kondor S, Moore M. Experimental Investigation of a Morphing Nacelle Ducted Fan. NASA, Smyrna, 2004.
- [9] Kritzing D. Aircraft system safety. Military and civil aeronautical applications. Woodhead Publishing, Cambridge, 2006.

- [10] Kritzinger D. Aircraft system safety. Assessments for initial airworthiness certification. Woodhead Publishing, Duxford, 2016.
- [11] Lloyd E, Tye W. Systematic Safety. CAA, London, 1982.
- [12] Ozdemir NG, Scarpa F, Craciun M, Remillat C, Lira C, Jagessur Y, Da Rocha-Schmidt L. Morphing nacelle inlet lip with pneumatic actuators and a flexible nano composite sandwich panel. Smart Mater. Struct., 2015, 24 (12), pp. 125018.
- [13] SAE Aerospace. ARP4761. SAE Aerospace, Warrendale, 1996.
- [14] SAE Aerospace. ARP4754A. SAE Aerospace, Warrendale, 2010.