

A comprehensive review on structural joining techniques in the marine industries

F. Delzendehrooy (INEGI, Portugal), A. Akhavan-Safar, A. Q. Barbosa, R. Beygi, D. Cardoso, R.J.C. Carbas, E.A.S. Marques, L.F.M. da Silva

Introduction

Since many modules of a ship cannot be practically reduced to a single structure, joining technologies are employed to join various substructures and transfer loads between the different components. These joining methods include welding, mechanical fastening, adhesive bonding, overlamination, and hybrid joining. In the current study, a comprehensive review has been conducted on the mechanical performance of the common joining techniques in the marine industry.

Joining techniques in the marine industry

Overlamination method which consists of two parts that are joined by lamination, is widely employed in marine industry due to number of benefits such as increase in the fatigue resistance, and reduction of the fasteners [1].

Adhesive bonding is generally employed when the design and manufacturing requirements involve thin substrates, corrosion resistance, particular materials, low weight, surface integrity, and minimum stress concentration [2].

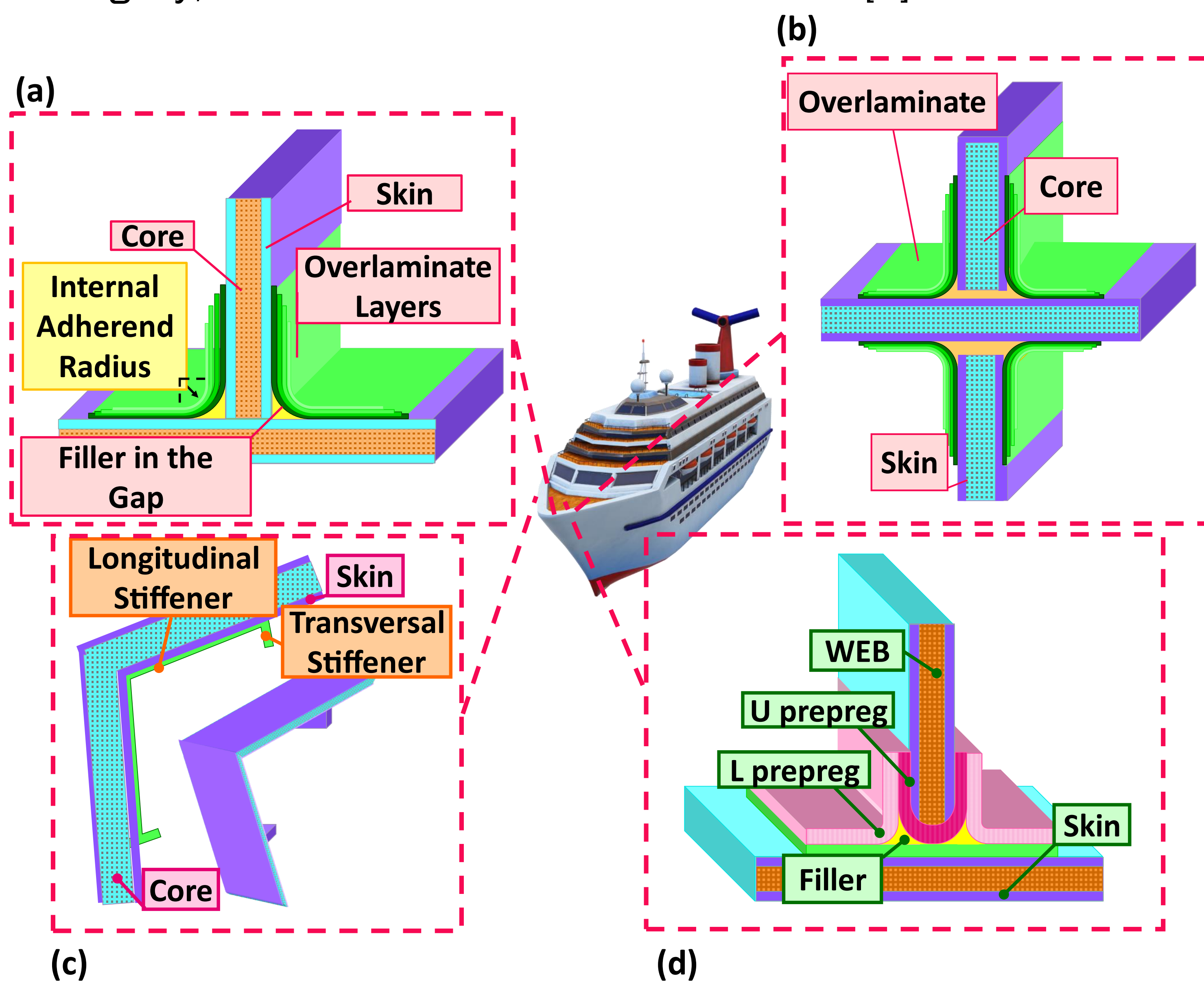

Figure 1 – typical overlaminated joints: a) T-Joint, b) X-Joint, c) L-Joint, and d) II-Joint

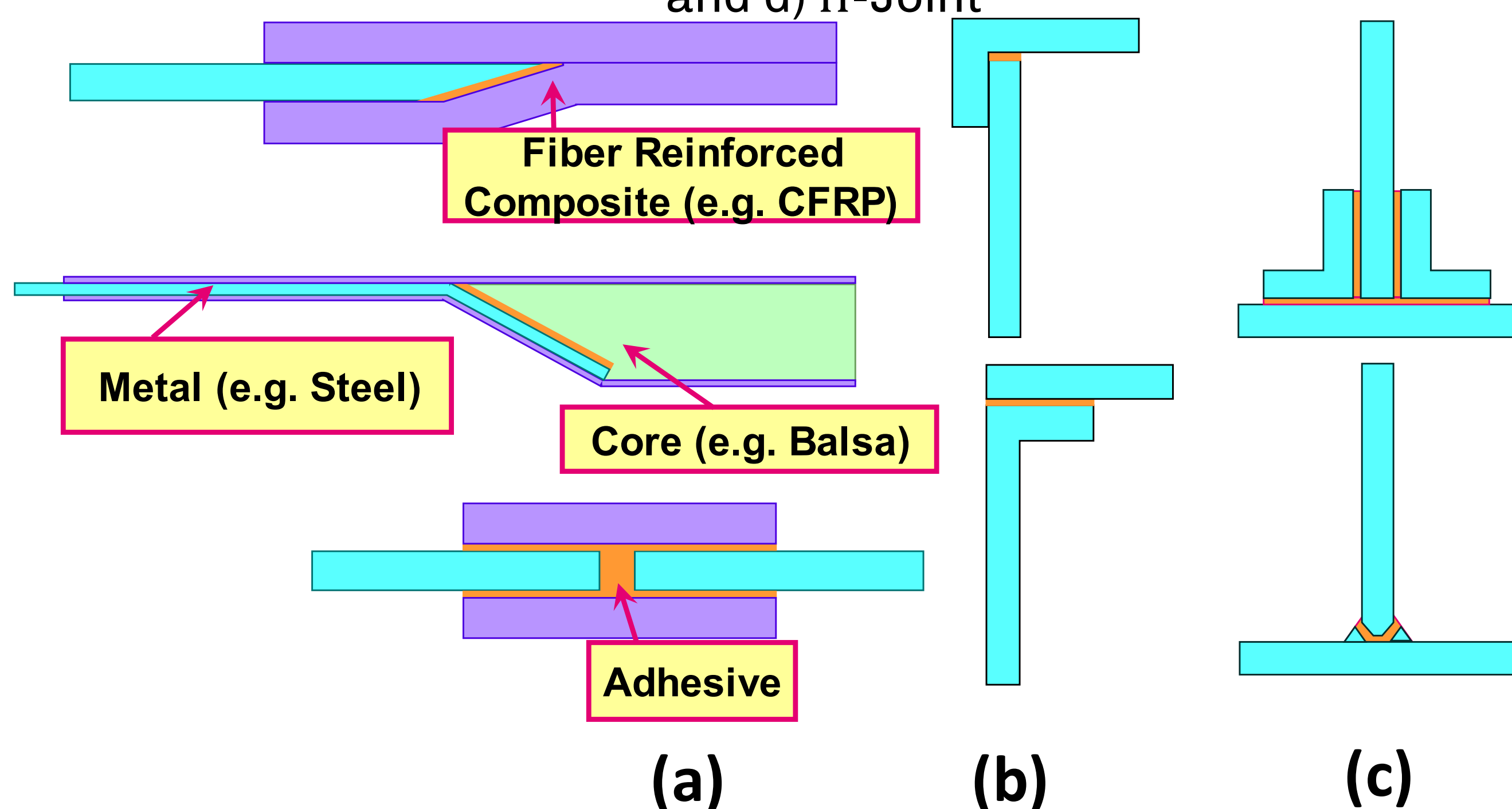

Figure 2 – typical types of adhesive joints: a) Butt-Joint, b) Corner-Joint, and c) T-Joint

Traditionally, welding has been employed to join components permanently. Welding processes can be classified into two main groups: fusion welding (for the thermoplastic polymer composites) and solid-state welding (for all types of polymer composites). Perhaps, the most common method within industry is mechanical fastening which can be used originally for metal joining as well as plastics to themselves and to other materials.

Since each of mentioned joining techniques provide some issues along with their advantages, the idea of hybrid joining method has been introduced to overcome the challenges.

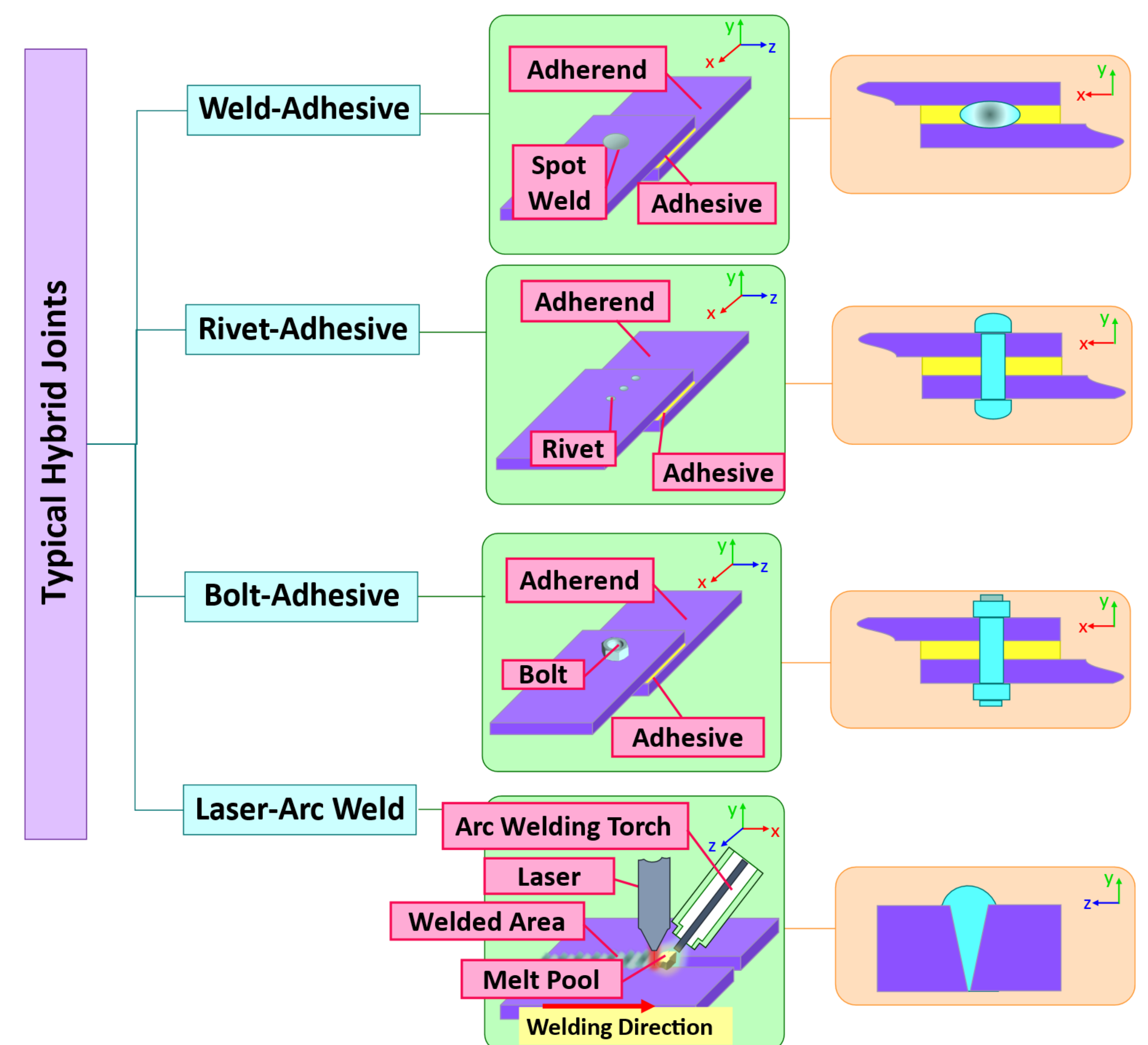

Figure 3 – Typical hybrid joints in the marine industry

Table 1 – Mechanical characterization of various joining methods in the marine industry

Concerning Prospect	Method				
	Welding	Adhesive Bonding	Mechanical Fastening	Overlamination	Hybrid Joining
Mechanical Performance					
Stress concentration at joint	Medium	Low	High	Low	Medium to high
Strength to weight ratio	Medium	High	Low	Low	Medium
Fatigue endurance	Medium	Good	Low	Good	Medium
Vibration absorption	Low	High	Low	High	Medium

Conclusions

Using suitable and efficient joining methods which maintain the integrity, reliability, and durability of the structure is a concerning issue that must be considered in joining components in marine structures. To design the most efficient joints to be used in the marine industry, criteria such as mechanical performance, manufacturing process, endurance against the environmental conditions, and the specific application of structure must be considered.

References

- [1] Feng Y, Qiu H, Gao Y, Zheng H, Tan J. Creative design for sandwich structures: A review. *International Journal of Advanced Robotic Systems*. 2020;17(3):1729881420921327.
- [2] da Silva LFM, Öchsner A, Adams RD. *Handbook of adhesion technology*: Springer Science & Business Media, 2011.
- [3] Zhi Q, Lu L, Liu Z, Wang P. Influence of Horn Misalignment on Weld Quality in Ultrasonic Welding of Carbon Fiber/Polyamide 66 Composite. *Welding Journal*. 2018;97(5):133S-143S.

Acknowledgements

This project has received funding from the European Union's Horizon 2020 research and innovation programme under grant agreement No 101006860 (FIBRE4YARDS project).